

**WARRANTY AND SOFTWARE LICENSE**

**SCOTTY GROUP PLC SOFTWARE LICENSE AGREEMENT**

Please read before using your SCOTTY product

By using your SCOTTY product you are indicating (1) your acceptance of the terms of this Software License Agreement ("License"); (2) your promise to use the "Software", which shall be deemed to include all software and embedded firmware provided with and incorporated into your SCOTTY product, whether in machine or user readable form, and all subsequent updates and enhancements thereof, as well as patents, copyrights, trademarks and trade secrets relating thereto, only as permitted by this License; and, (3) your promise to protect the Software from unauthorized use, duplication, distribution, or publication.

**GRANT OF LICENSE:** You are hereby granted non-exclusive License to use the Software in conjunction with your use of your SCOTTY product subject to the terms, conditions, and limitations herein provided. Title to the Software shall remain the property of SCOTTY Group plc hereinafter called "SCOTTY", or the original licensor as regards included computer software licensed to SCOTTY for sublicensing. All rights not specifically granted to you are hereby reserved by SCOTTY.

**PERMITTED USES:** You may (1) use the software only in conjunction with your use of the SCOTTY product with which it was provided; (2) rent, loan, or lease the software, but only in conjunction with the rent, loan, or lease of the SCOTTY product with which it was provided and only if the recipient accepts the terms of this License; and (3) transfer possession of the Software but only in conjunction with the transfer of sale of the SCOTTY product with which it was provided and only if the recipient accepts the terms of this License.

**PROHIBITED ACTIONS:** You may not: (1) make copies of the Software or any documentation accompanying the Software; (2) alter, merge, or modify the Software in any way, nor decompile, disassemble or reverse-engineer the same; (3) rent, loan, or lease the Software apart from the rent, loan, or lease of the SCOTTY product with which it was provided; (4) remove, deface or obscure trademarks or copyright notices embedded within the Software or appearing upon the documentation accompanying the same; or (5) transfer possession of the software separate and apart from the transfer or sale of the SCOTTY product with which it was provided.

**TERM:** The term of this License shall be indefinite and it shall continue in full force and effect until terminated by either of party as herein provided. You may terminate this license at any time by destroying the Software. SCOTTY may terminate this License at any time upon your breach of the terms of this License. Upon termination by SCOTTY, you agree to destroy or permit SCOTTY to destroy the software including all copies thereof.

**US GOVERNMENT RESTRICTED RIGHTS:** The Software and the documentation accompanying the software are provided with RESTRICTED RIGHTS. Use, duplication, or disclosure by the Government is subject to restrictions as set forth in subparagraph ©(f)(i) of The Rights in Technical Data and Computer Software clause at DFARS 252.227-7013 or subparagraphs (c)(1) and (2) of the Commercial Computer Software- restricted Rights at 48 CFR 52.227-19, as applicable. Contractor/manufacturer is SCOTTY Group of the Americas, 6714 Netherlands Drive, Wilmington, NC 28405.

**EXPORT RESTRICTIONS:** You agree that you will not export, re-export, resell, ship or divert, directly or indirectly, the Software or a derivative of the same to any country for which the United States Government or any agency thereof requires a validated export license or other governmental approval for export without first obtaining such license or approval. You also agree that you will not export, re-export, resell, ship or divert, directly or indirectly, the Software or a derivative of the same to any person, party or entity whatsoever whom you know or have reason to know will utilize the same in the design, development, or production of nuclear, chemical, or biological weapons, or ballistic missiles.

The SCOTTY logo is a registered trademark of SCOTTY Group plc.

**Technical Support:** 1-910-395-6100  
**Web:** <http://www.scottysgroup.com>

**ONE YEAR LIMITED PRODUCT WARRANTY**

SCOTTY GROUP plc ("SCOTTY") warrants to the original purchaser ("You") that your SCOTTY product will be in good working order under normal operating conditions for a period of one (1) year from the date of purchase as evidenced by a dated sales receipt. If during the warranty period your SCOTTY product is found not to perform as warranted, SCOTTY will provide all parts and labor necessary to repair or replace it.

SCOTTY will not accept the unauthorized return of any product. To obtain warranty service, You must first call the SCOTTY Customer Support Department during normal working hours (9A.M to 5 P.M. EST) at 1-910-395-6100 and provide a description of the problem experienced. An "RMA" number will be assigned for each authorized return. You must then: (1) prominently mark the "RMA" number assigned on the outside of the shipping carton containing the returned product (2) enclose a copy of your dated sales receipt, a brief description of the problem experienced as well as your name, telephone number and return address. (3) properly package your SCOTTY product in a manner that will ensure its safe arrival, and (4) prepay the return shipping charges. Failure to comply with any of these instructions may result in a delay of warranty service.

In its sole discretion SCOTTY may use new, used or refurbished parts or products to repair or to replace defective parts or products, and all replaced parts or products shall become the property of SCOTTY. Replacement parts or products, whether new, used or refurbished, will be warranted for the remainder of the original warranty period or for a period of thirty (30) days, whichever is longer. Products manufactured by third parties and sold by SCOTTY are specifically excluded from this warranty.

THIS LIMITED WARRANTY IS MADE IN LIEU OF ALL OTHER WARRANTIES, EITHER EXPRESS OR IMPLIED, WRITTEN OR ORAL, INCLUDING WITHOUT LIMITATION THE IMPLIED WARRANTIES OF MERCHANTABILITY AND FITNESS FOR A PARTICULAR PURPOSE, AND EXCEPT AS HEREIN OTHERWISE PROVIDED, YOUR SCOTTY PRODUCT IS DELIVERED "AS IS" WITHOUT WARRANTY OF ANY KIND.

NEITHER SCOTTY, OR ITS AUTHORIZED RETAIL DEALERS SHALL BE LIABLE TO YOU, OR TO ANY OTHER PARTY, FOR ANY SPECIAL, INCIDENTAL OR CONSEQUENTIAL DAMAGES OR FOR ANY LOSS, DAMAGE, OR EXPENSE WHATSOEVER, WHETHER DIRECT OR INDIRECT, ARISING FROM OR OUT OF THE USE, THE INABILITY TO USE, OR THE MISUSE OF YOUR SCOTTY PRODUCT INCLUDING PERSONAL INJURY OR THE LOSS OR DESTRUCTION OF ANY OTHER PROPERTY WHICH DAMAGES ARE HEREBY EXPRESSLY WAIVED. SOME JURISDICTIONS PROHIBIT THE EXCLUSION OR LIMITATION OF DAMAGES AND IMPLIED WARRANTIES; THEREFORE THESE EXCLUSIONS MAY NOT APPLY TO YOU.

Damage to your SCOTTY product resulting from improper packaging for return shipment, abuse, improper use, negligence, vandalism, accident, such intervening causes as fire, flood, electrical voltage surge or drop whether due to a lightning strike or other cause, and acts of God are expressly and specifically excluded from coverage under this warranty. Moreover, this warranty shall become null and void of no legal effect if and in the event that your SCOTTY product is used outside of the normal operating environment for which it was designed, if the product is altered or modified in any manner, if any of the original identification markings, including trademarks or serial numbers, are altered, defaced or removed, if any factory seal is broken, or if repairs are attempted by any party other than SCOTTY, and in any event, SCOTTY's liability shall not exceed the purchase price paid.

**REGISTRATION**

Please register your SCOTTY product by visiting our web site [www.scottysgroup.com/registration](http://www.scottysgroup.com/registration).

Alternatively, write to the following address with your name, company, address, where purchased, the date purchased, the model and serial number of the unit.

**SCOTTY Group of the Americas, 6714 Netherlands Drive, Wilmington, NC 28405, USA.**



# Getting Started

## Quick Installation Guide for the eyesite 140



Congratulations on the purchase of your eyesite 140!

This Quick Installation Guide provides an easy step-by-step installation procedure.

For more detailed installation information please refer to the eyesite 140 User Manual on the enclosed CD-ROM.



## Important Safety Information

- › Do not dismantle the eyesite 140. There are no user serviceable parts inside. Access to the inside of this unit should only be carried out by approved service personnel.
- › Keep the eyesite 140 away from water and other liquids (except when cleaning, as directed below). If you suspect that liquid has entered the equipment, immediately disconnect the unit from the network and from the power supply, ensuring first that your hands and the power supply outlet area are dry. Do not use the eyesite 140 again until it is thoroughly dry.
- › Clean the case only with a soft, lint-free cloth, either dry or slightly dampened with water. Disconnect the power and the network cables before using a damp cloth to clean the eyesite 140.
- › Before connecting any equipment that was not supplied with the eyesite 140, check the specification to ensure compatibility.
- › Do not use the eyesite 140 if you suspect a gas leak. Operation of any electrical equipment can generate sparks which may ignite the gas and cause an explosion.
- › Do not let cables trail where they might cause someone to trip or pull the eyesite 140 onto the floor.
- › Use only on a stable surface. The eyesite 140 may be damaged if it falls.
- › Keep the equipment and its packaging out of reach of small children.
- › Do not push objects into the ventilation holes.
- › Do not block the ventilation slots as this could cause the equipment to overheat and malfunction.
- › Do not place the eyesite 140 in direct sunlight. Do not point any external cameras directly at the sun as this is likely to cause serious damage to the unit.
- › The eyesite 140 will not function in the event of a power cut. It should not be relied upon as the only means of contacting the emergency services.

## Step 1: Unpack and Check Contents

- › Please unpack the eyesite 140 and check the contents for damage. The following items are supplied with the eyesite 140:

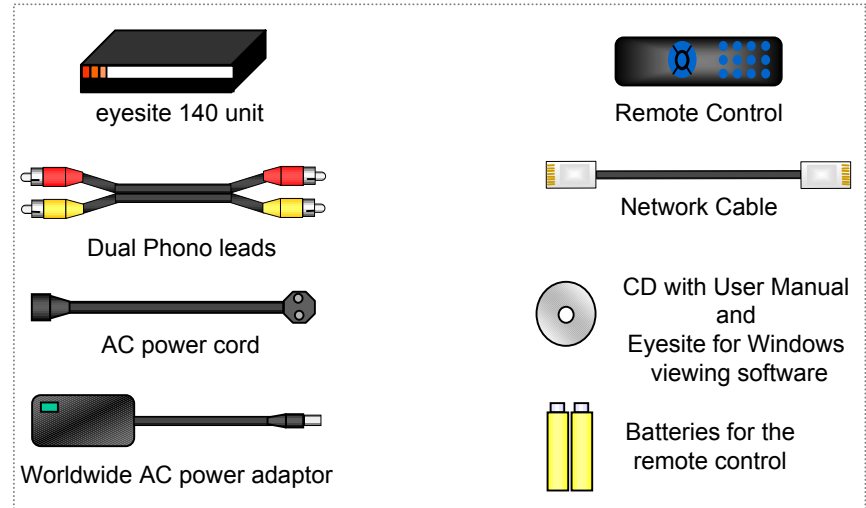

- › Optional accessories for the eyesite 140 include:

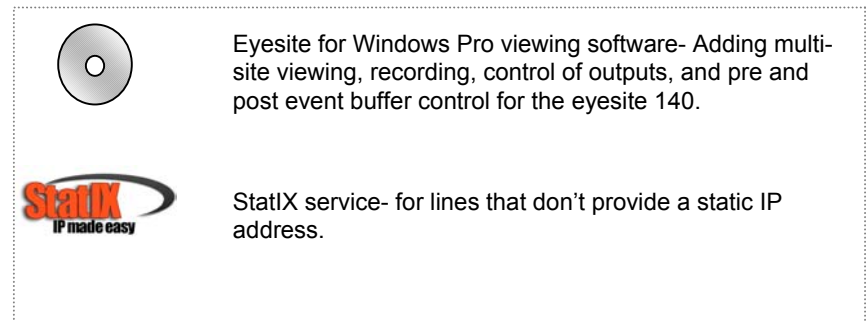

## Step 2: Connect to Power and Network

### Connecting Power

- › Connect the power cable to the power supply, then connect the DIN connector to the rear of the eyesite 140 and the AC connector to your power outlet.
- › The red PWR LED indicator on the front of the eyesite 140 indicates that it has power.
- › The green Stat LED on the front of the eyesite 140 flashes as the unit starts up, and stays on continuously when this process is complete.

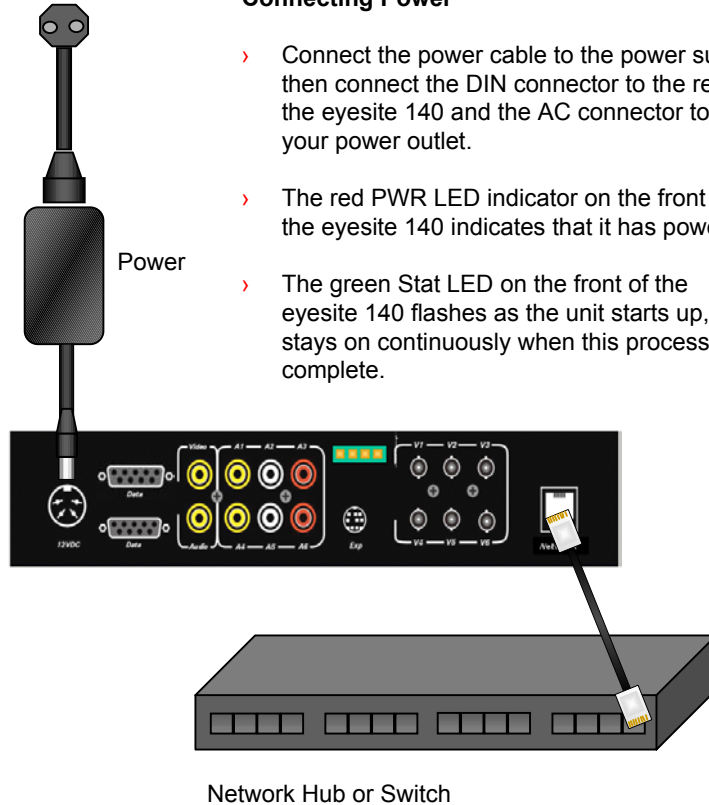

### Connecting to the Network

- › Connect the supplied black Cat5 network cable between the connector labeled 'Network' to a 10 Mbps network hub or switch.
- › The green Net LED goes on permanently when the eyesite 140 is correctly connected to the network.

## Step 3: Connect Video and Audio

- › Insert the supplied AAA batteries into the remote control
- › Connect cameras to the BNC connectors labeled Video in. Cameras or video inputs must supply a PAL or NTSC composite video signal.
- › Connect the yellow video out connector to the video input of your TV or monitor and connect the audio out connector to the audio input of your TV or monitor.

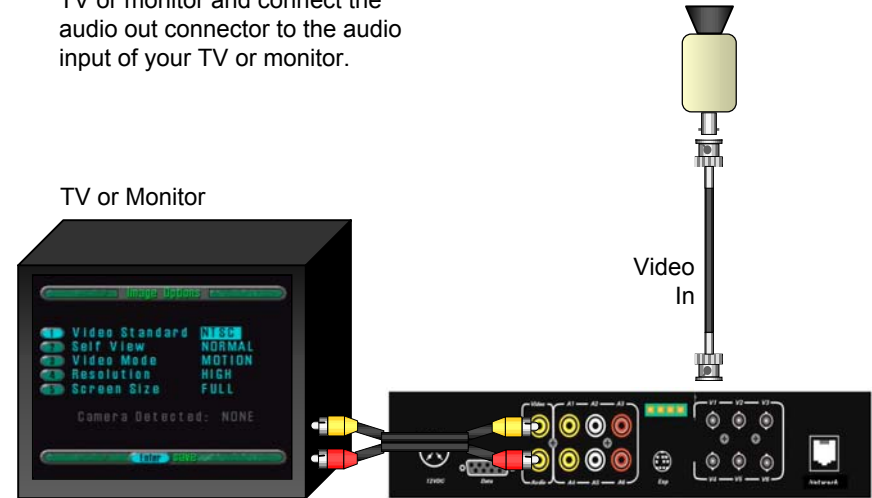

### Selecting the correct video standard

- › If the TV screen image rolls or there is a loss of colour you need to change the format from NTSC to PAL or from PAL to NTSC, otherwise move on to Step 4.
- › Using the remote control, press the following buttons:
- › **MENU** (Main Menu), **4** (Image Options), **1** (Video Standard), **Right Arrow** (Change standard PAL or NTSC), **ENTER** (save standard), **ENTER** (Save image options), **EXIT** (exit menu).

## Step 4: Connect to Alarm Ports

To make the eyesite 140 dial automatically in the event of an alarm:

- › Data Port # 1 can be connected to a volt free contact, such as a sensor, door or window contact, or alarm panel output. For this to operate
  - › The Data Type is DATA (See below)
  - › The phonebook must have an entry (Step6)
  - › The autodialer must be set to ALARM (Step 7)
- › To enable the data port to sense alarms press **MENU, 6** (Data Port Options), **1** (Type), **Right Arrow** (to select type DATA).
- › Press **ENTER, ENTER, EXIT** to save and exit.

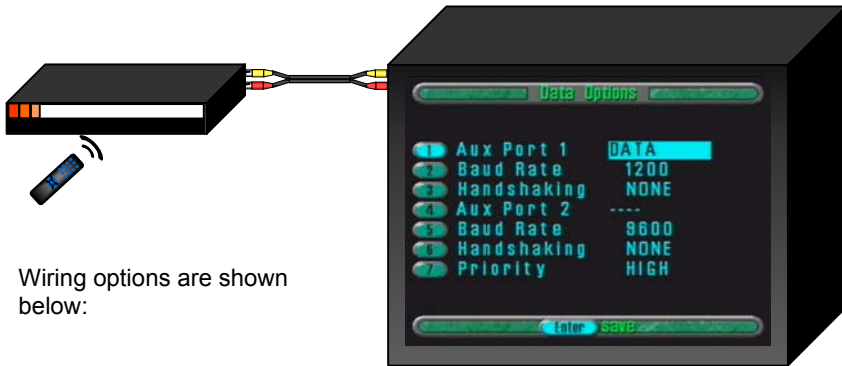

- › Wiring options are shown below:

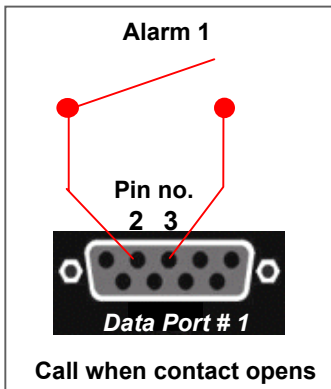

or

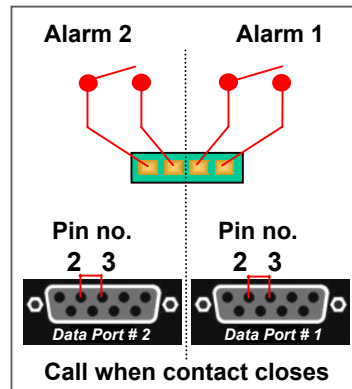

## Step 5: Configure an IP Address

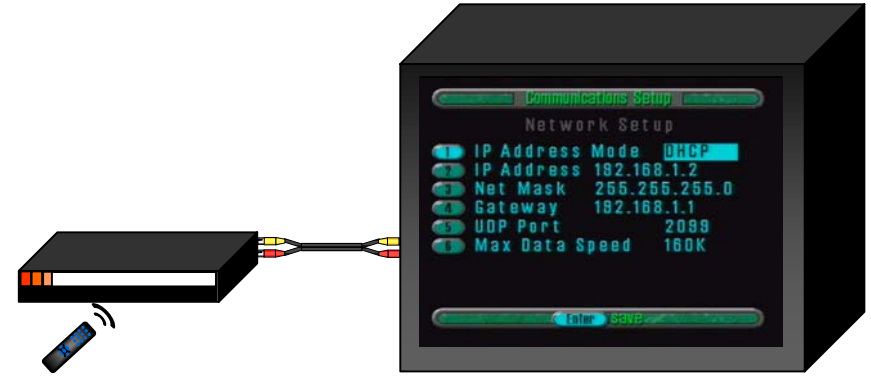

- › Obtain an IP address, subnet mask, and default gateway address from your network provider or use DHCP to obtain an address automatically.

- Press **MENU** (Main Menu)
- Press **2** (Communications Setup)
- Press **1** (Network Setup)

### Manual (Static) Address:

- Select TYPE Static using the Right Arrow key
- IP Address Enter using number keys and "\*" key to represent a "."
- Subnet Mask Enter the subnet mask e.g. 255.255.255.0
- Gateway Enter the address of your router or firewall

Or

### Automatic (DHCP) Address

- Select TYPE DHCP using the arrow keys.
- Press **ENTER**
- Now select TYPE Static to prevent IP address changes from making your eyesite 140 unit inaccessible.

5. Press **ENTER** twice to save your address.
6. If you are not working from behind a firewall your IP configuration is complete.

## Step 6: Create an entry in the phonebook

- › To edit the phonebook press the **MENU** button and select option 1 (Edit Address Directory)
- › Enter the name of the site you want to call using the letter/number keys and the right arrow to move to the next letter. Press **ENTER** to store the name.
- › Select the call speed depending on the available bandwidth on your line using the left and right arrows and press **ENTER** to store the selected speed.
- › Enter the IP address or StatIX number of the unit you wish to dial using the number keys and press **ENTER** to store the number. Use the **Right Arrow** key or \* key to make a "." in an IP address
- › Enter the PIN number of the selected site if you require PIN authorisation and press **ENTER** to save this entry.
- › Add other locations by pressing the right arrow to edit another entry.
- › Press **ENTER** and **EXIT** to leave the menu system.

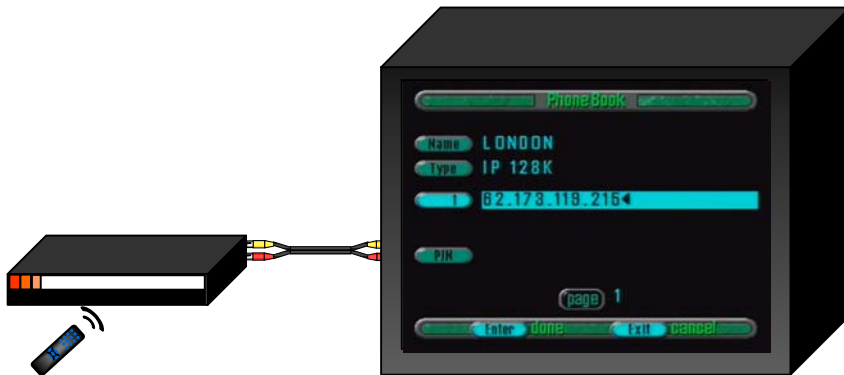

## Step 7: Autodial and Auto Answer

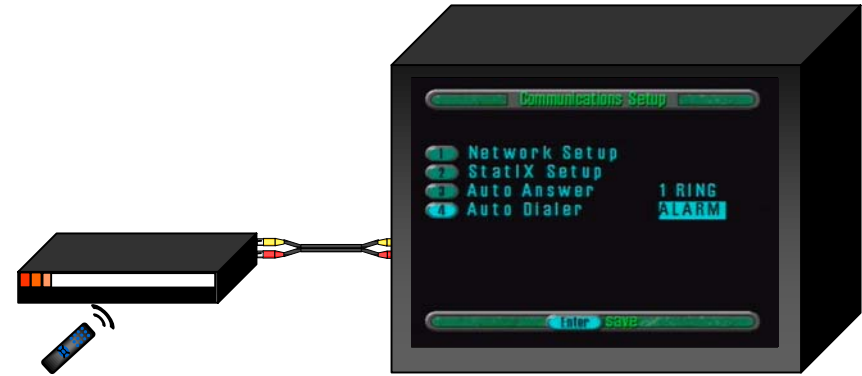

- › **To set up Auto Answer:**
- › If you wish to dial into the eyesite 140 when it is unattended you need to set up Auto Answer.
- › Press the **MENU** button (Main Menu) and select number **2** (Communications Setup).
- › Select option **3** (Auto Answer) and use the right arrow to change the number of rings to **1 RING**. Press **ENTER** to store the setting.
- › **To set up the Auto Dialer:**
- › Select option **4** (Auto Dialer) and use the right arrow to select your desired option.
- › ALARM causes the unit to dial the number in phonebook location 1 when a normally closed pair of contacts attached to the alarm port is opened.
- › AUTO causes the unit to dial the number in phonebook location 1 permanently.
- › Press **ENTER** to store your desired selection.
- › Press **ENTER** and **EXIT** to leave the menu system.

## Step 8: Configure your firewall

If you are connecting from behind a firewall this port forwarding example may help you to choose the best settings.

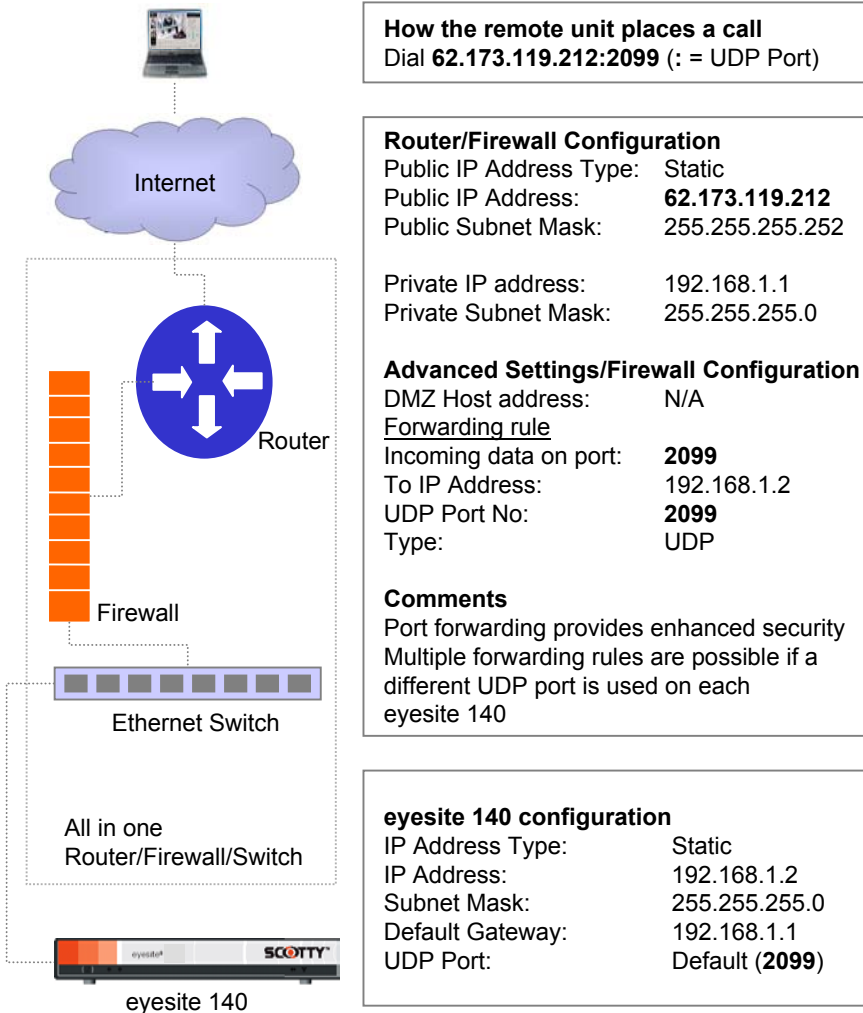

**How the remote unit places a call**  
Dial **62.173.119.212:2099** (: = UDP Port)

**Router/Firewall Configuration**  
Public IP Address Type: Static  
Public IP Address: **62.173.119.212**  
Public Subnet Mask: 255.255.255.252

Private IP address: 192.168.1.1  
Private Subnet Mask: 255.255.255.0

**Advanced Settings/Firewall Configuration**  
DMZ Host address: N/A  
Forwarding rule  
Incoming data on port: **2099**  
To IP Address: 192.168.1.2  
UDP Port No: **2099**  
Type: UDP

**Comments**  
Port forwarding provides enhanced security  
Multiple forwarding rules are possible if a different UDP port is used on each eyesite 140

**eyesite 140 configuration**  
IP Address Type: Static  
IP Address: 192.168.1.2  
Subnet Mask: 255.255.255.0  
Default Gateway: 192.168.1.1  
UDP Port: Default (**2099**)

## Step 9: Install eyesite for Windows

- › Insert the supplied CD in your PC's CD drive.
- › Browse to the CD drive and select the Install Now option.
- › Follow the on-screen instructions to install eyesite for Windows.

<p><b>Connect</b> 1. Click 'Connect' 2. Click 'Add' and enter the IP address of your eyesite 140</p>	<p><b>Options</b> Click Options Check the IP box Check the auto answer box</p>	<p><b>Call Info</b> For last call Diagnosis</p>	<p><b>Zone and Camera Selection</b> Select zone from 1-6 or press SEQ to cycle through the cameras.</p>
<p><b>Help</b> Use the help file for information and fault finding</p>			
<p><b>Recorder Control</b> Recording and image control</p>			
<p><b>Snapshots</b> Drag and drop snapshots Right click to view or save images</p>	<p><b>Camera Control</b> Pan, Tilt, Zoom</p>	<p><b>Presets</b> Access and set preset camera positions stored in your PTZ camera</p>	<p><b>Zone Control</b> For controlling audio and alarm inputs and outputs (eyesite 550).</p>

**NOTE:** Certain functions are provided for evaluation purposes and will expire after 45 days. You may upgrade your software to make these permanent.